

DOI 10.24425/ae.2018.124750

Non-proportional full-order Luenberger observers of induction motors

TADEUSZ BIAŁOŃ¹, ARKADIUSZ LEWICKI², MARIAN PASKO¹, ROMAN NIESTRÓJ¹,

¹ *Institute of Electric Engineering and Computer Science, Silesian University of Technology
Akademicka 10, 44-100 Gliwice, Poland*

² *Department of Electric Drives and Energy Conversion, Gdańsk University of Technology
Sobieskiego 7, 80-216 Gdańsk, Poland
e-mail: tadeusz.bialon@polsl.pl*

(Received: 05.06.2018, revised: 22.09.2018)

Abstract: The paper recapitulates recently conducted investigations of non-proportional Luenberger observers, applied to reconstruction of state variables of induction motors. Three structures of non-proportional observers are analyzed, a proportional-integral observer, modified integral observer and observer with integrators. Criteria for gain selection of the observer are described, classical ones based on poles, as well as additional, increasing observer's robustness. Fulfilment of the presented criteria can be ensured with the three proposed methods for gain selection, two analytical, based on dyadic transformation and one based on optimization.

Key words: Luenberger observer, induction motor, pole placement

1. Introduction

From among all known types of Luenberger observers only proportional ones are commonly applied in induction motor control systems [1]. Observers with feedbacks other than proportional are more difficult to apply, however, they potentially provide better quality of state variable reconstruction. An exemplary non-proportional observer is a proportional-integral observer [2–5] that provides stronger reconstruction error attenuation than a proportional observer. Another non-proportional observer, a proportional observer with integrators [6, 7], has the ability of alleviating the disadvantageous impact of unknown disturbances present in an observed system. The third of analyzed non-proportional observers, a modified integral observer [2, 3, 8], is characterized by better robustness against disturbances overlaying observed system outputs.

2. Mathematical model of an induction motor

The first step of observer design consists in the creation of an observed system's mathematical model. A linear dynamic system with n -element state vector \mathbf{x} , p -element input vector \mathbf{u} , q -element output vector \mathbf{y} and z -element vector \mathbf{d} containing unknown disturbances, can be described with a standard form set of matrix equations:

$$\begin{cases} \dot{\mathbf{x}} = \mathbf{A}\mathbf{x} + \mathbf{B}_2\mathbf{u} + \mathbf{B}_1\mathbf{d} \\ \mathbf{y} = \mathbf{C}\mathbf{x} \end{cases} \quad (1)$$

In (1) $\dot{\mathbf{x}}$ denotes the derivative over time of state vector \mathbf{x} , \mathbf{A} , \mathbf{B}_1 , \mathbf{B}_2 and \mathbf{C} are the real matrices with proper dimensions and values dependent on equivalent circuit parameters of the motor. Moreover, element values of the matrix \mathbf{A} are dependent also on the angular speed of the motor ω , treated as a parameter [1, 8]. Matrix equations (1) are derived from differential equations describing an induction motor in transient states and algebraic equations of magnetic couplings [9]:

$$\begin{cases} \dot{\psi}_{s\alpha} + R_s i_{s\alpha} = u_{s\alpha} \\ \dot{\psi}_{s\beta} + R_s i_{s\beta} = u_{s\beta} \\ \dot{\psi}_{r\alpha} + (\omega - \delta\omega)\psi_{r\beta} + R_r i_{r\alpha} = 0 \\ \dot{\psi}_{r\beta} - (\omega - \delta\omega)\psi_{r\alpha} + R_r i_{r\beta} = 0 \end{cases}, \quad \begin{cases} \psi_{s\alpha} = L_s i_{s\alpha} + L_m i_{r\alpha} \\ \psi_{s\beta} = L_s i_{s\beta} + L_m i_{r\beta} \\ \psi_{r\alpha} = L_r i_{r\alpha} + L_m i_{s\alpha} \\ \psi_{r\beta} = L_r i_{r\beta} + L_m i_{s\beta} \end{cases} \quad (2)$$

In (2) by $\psi_{s\alpha}$ and $\psi_{s\beta}$ magnetic fluxes coupled with the stator winding are marked in the axes α and β of the stationary Cartesian coordinate system, respectively, $\psi_{r\alpha}$ and $\psi_{r\beta}$ denote the fluxes coupled with the rotor winding. Similarly, $i_{s\alpha}$, $i_{s\beta}$, $i_{r\alpha}$ and $i_{r\beta}$ mark the currents of the stator and rotor windings. Supply voltages of stator winding are denoted as $u_{s\alpha}$ and $u_{s\beta}$. Constant equivalent circuit parameters are denoted by R_s , R_r , L_s , L_r and L_m [9, 10].

It is assumed that the state variables of the motor $\psi_{s\alpha}$, $\psi_{s\beta}$, $\psi_{r\alpha}$ and $\psi_{r\beta}$ are included in the state vector \mathbf{x} , the inputs $u_{s\alpha}$ and $u_{s\beta}$ create the input vector \mathbf{u} , outputs $i_{s\alpha}$ and $i_{s\beta}$ form an output vector \mathbf{y} . Additionally, disturbance $\delta\omega$ was introduced in (2), symbolizing the difference between the actual angular speed of the motor and the speed ω measured or reconstructed and passed to the observer as a parameter. The $\delta\omega$ signal is used only during the synthesis of a proportional observer with additional integrators, in other cases it is omitted ($\delta\omega = 0$). Successive vectors of the mathematical model (1) of the observed system assume forms:

$$\mathbf{x} = \begin{bmatrix} \psi_{s\alpha} \\ \psi_{s\beta} \\ \psi_{r\alpha} \\ \psi_{r\beta} \end{bmatrix}, \quad \mathbf{u} = \begin{bmatrix} u_{s\alpha} \\ u_{s\beta} \end{bmatrix}, \quad \mathbf{y} = \begin{bmatrix} i_{s\alpha} \\ i_{s\beta} \end{bmatrix}, \quad \mathbf{d} = \begin{bmatrix} -\psi_{r\alpha}\delta\omega \\ \psi_{r\alpha}\delta\omega \end{bmatrix} \quad (3)$$

From the forms of vectors (3) it follows that for the mathematical model of the induction motor $n = 4$, $p = q = z = 2$.

3. Structures of the observers

State vector \mathbf{x} of observed system (1) can be reconstructed with observers that have various types of feedbacks. Each of them has its advantages and drawbacks that occur in particular operating conditions.

A proportional-integral observer (PI) can be applied when the reconstruction quality provided by a classic proportional observer is too low due to presence of excessive measurement noises. Better operation of the PI observer is provided in such conditions by stronger feedback [2–4]. The state equation of the PI observer assumes the form:

$$\dot{\hat{\mathbf{x}}} = \mathbf{A} \hat{\mathbf{x}} + \mathbf{B}_2 \mathbf{u} + \mathbf{K}_P (\mathbf{C} \hat{\mathbf{x}} - \mathbf{y}) + \mathbf{K}_I \int_0^t (\mathbf{C} \hat{\mathbf{x}} - \mathbf{y}) \, d\tau, \quad (4)$$

where \mathbf{K}_P and \mathbf{K}_I denote the real gain matrices of proportional and integral feedback elements. The reconstructed state vector of system (1) is marked by $\hat{\mathbf{x}}$. The PI observer provides potentially better reconstruction quality than proportional one, however, it has twice as many state variables and gains that makes its design more complicated. Another significant drawback is the structural instability of the PI observer that occurs for some specific classes of the observed system, independently of observer gains [4].

In the case when observed system (1) is driven with unknown disturbances included in vector \mathbf{d} , their negative impact on reconstruction quality can be alleviated with use of an observer with integrators [6]. Its state equation has the form:

$$\dot{\hat{\mathbf{x}}} = \mathbf{A} \hat{\mathbf{x}} + \mathbf{B}_2 \mathbf{u} + \mathbf{K}_P (\mathbf{C} \hat{\mathbf{x}} - \mathbf{y}) + \mathbf{B}_1 \sum_{k=1}^{\nu} \mathbf{K}_{\nu-k+1} \underbrace{\int_0^t \cdots \int_0^t}_{\nu} (\mathbf{C} \hat{\mathbf{x}} - \mathbf{y}) \, d\tau^{\nu}, \quad (5)$$

where \mathbf{K}_i denotes the gain matrix of the i -th additional integrator and ν is the number of applied additional integrators. The greater the number of integrators, the stronger is compensation of reconstruction errors caused by the presence of unknown disturbances. However, when more integrators are applied, observer's robustness against measurement noises included in outputs \mathbf{y} of observed system (1) is less. Another drawback of this observer is also possibility of structural instability occurrence [7].

It can be proven [2, 3], that if the gains of the proportional and PI observers rise, the robustness against measurement noises drops. This effect limits the possibility design of a high-gain observer, characterized by strong reconstruction error attenuation. This effect does not occur in a modified integral observer [3], described with the state equation:

$$\begin{cases} \dot{\boldsymbol{\xi}} = \mathbf{A}_{\boldsymbol{\xi}} \boldsymbol{\xi} + \mathbf{B}_{\boldsymbol{\xi}} \mathbf{u} + \mathbf{K}_{\boldsymbol{\xi}} \left(\mathbf{C}_{\boldsymbol{\xi}1} \boldsymbol{\xi} - \int_0^t \mathbf{y} \, d\tau \right), \\ \hat{\mathbf{x}} = \mathbf{C}_{\boldsymbol{\xi}2} \boldsymbol{\xi} \end{cases}, \quad (6)$$

where $\mathbf{K}_{\boldsymbol{\xi}}$ denotes the real gain matrix. The state vector of the observer $\boldsymbol{\xi}$ has greater number of elements than the state vector \mathbf{x} of observed system (1). Matrices of the observer assume the

forms:

$$A_{\xi} = \begin{bmatrix} \mathbf{A} & \mathbf{0}_{n \times q} \\ \mathbf{C} & \mathbf{0}_{q \times q} \end{bmatrix}, \quad B_{\xi} = \begin{bmatrix} \mathbf{B}_2 \\ \mathbf{0}_{q \times p} \end{bmatrix}, \quad B_{\xi 1} = [\mathbf{0}_{q \times n} \quad \mathbf{1}_q], \quad C_{\xi 2} = [\mathbf{1}_n \quad \mathbf{0}_{n \times q}]. \quad (7)$$

In (7) $\mathbf{1}_n$ denotes the identity matrix of n -th order and $\mathbf{0}_{i \times j}$ denotes the i -row j -column null matrix. The most significant drawback of this observer is tendency to constant component cumulation.

Problems with instability and constant component cumulation that occur in non-proportional observers described with (4), (5) and (6) demand modification of their structures. Modification that consists in replacing integrators in observer's feedback with first-order inertia has been proposed [11]. On application of this modification, it is always possible to provide stability of the observer by proper gains selection, and cumulated value of constant component can be limited as well.

4. Characteristic polynomial of the observer

Analysis of observer's dynamical properties and its gain selection is based on its characteristic polynomial $\phi(s)$. In order to derive the characteristic polynomial of a given observer, its mathematical model has to be transformed to the form of an equivalent proportional observer as follows:

$$\dot{\mathbf{x}}_o = \mathbf{A}_o \mathbf{x}_o + \mathbf{K}_o (\mathbf{C}_o \mathbf{x}_o - \mathbf{y}). \quad (8)$$

The state vector of equivalent proportional observer \mathbf{x}_o has n_o elements. Inputs and disturbances are omitted in (8), because they have no influence on a gain selection process. The characteristic polynomial of observer (8) assumes the form:

$$\phi(s) = \det(\mathbf{A}_o + \mathbf{K}_o \mathbf{C}_o - s \mathbf{1}_{n_o}) = \prod_{i=1}^{n_o} (s - \lambda_i), \quad (9)$$

where λ_i denotes the i -th root of the characteristic polynomial, also called the eigenvalue or the pole of the observer. The forms of matrices \mathbf{A}_o , \mathbf{K}_o and \mathbf{C}_o in (8) depend on type of observer's feedback. The observer's feedback type determines also the number n_o of state variables of equivalent proportional observer (8). For the PI observer described with (4), the number of state variables $n_o = 2n$, and matrices assume the forms:

$$\mathbf{A}_o = \begin{bmatrix} \mathbf{A} & \mathbf{1}_n \\ \mathbf{0}_{n \times n} & -\omega_c \mathbf{1}_n \end{bmatrix}, \quad \mathbf{C}_o = [\mathbf{C} \quad \mathbf{0}_{q \times n}], \quad \mathbf{K}_o = \begin{bmatrix} \mathbf{K}_P \\ \mathbf{K}_I \end{bmatrix}, \quad (10)$$

where ω_c is the inverse of the inertia time constant of modified integrators in the observer's feedback. For the observer with integrators, described with (5), $n_o = n + z\nu$:

$$\mathbf{A}_o = \begin{bmatrix} \mathbf{A} & \mathbf{0}_{n \times z(\nu-1)} & \mathbf{B}_1 \\ \mathbf{0}_{z \times n} & \mathbf{0}_{z \times z(\nu-1)} & \mathbf{0}_{z \times z} \\ \mathbf{0}_{z(\nu-1) \times n} & \mathbf{1}_{z(\nu-1)} & \mathbf{0}_{z(\nu-1) \times z} \end{bmatrix} + \begin{bmatrix} \mathbf{0}_{n \times n} & \mathbf{0}_{n \times z\nu} \\ \mathbf{0}_{z\nu \times n} & -\omega_c \mathbf{1}_{z\nu} \end{bmatrix}, \quad \mathbf{K}_o = \begin{bmatrix} \mathbf{K}_P \\ \mathbf{K}_I \\ \vdots \\ \mathbf{K}_\nu \end{bmatrix}, \quad (11)$$

$$C_o = \begin{bmatrix} C & \mathbf{0}_{q \times zv} \end{bmatrix}. \quad (12)$$

For the modified integral observer, described with (6), $n_o = n + q$:

$$A_o = \begin{bmatrix} A & \mathbf{0}_{n \times q} \\ C & -\omega_c \mathbf{1}_q \end{bmatrix}, \quad K_o = K_\xi, \quad C_o = C_{\xi 1}. \quad (13)$$

Block diagrams of all the discussed observers are shown in Fig. 1.

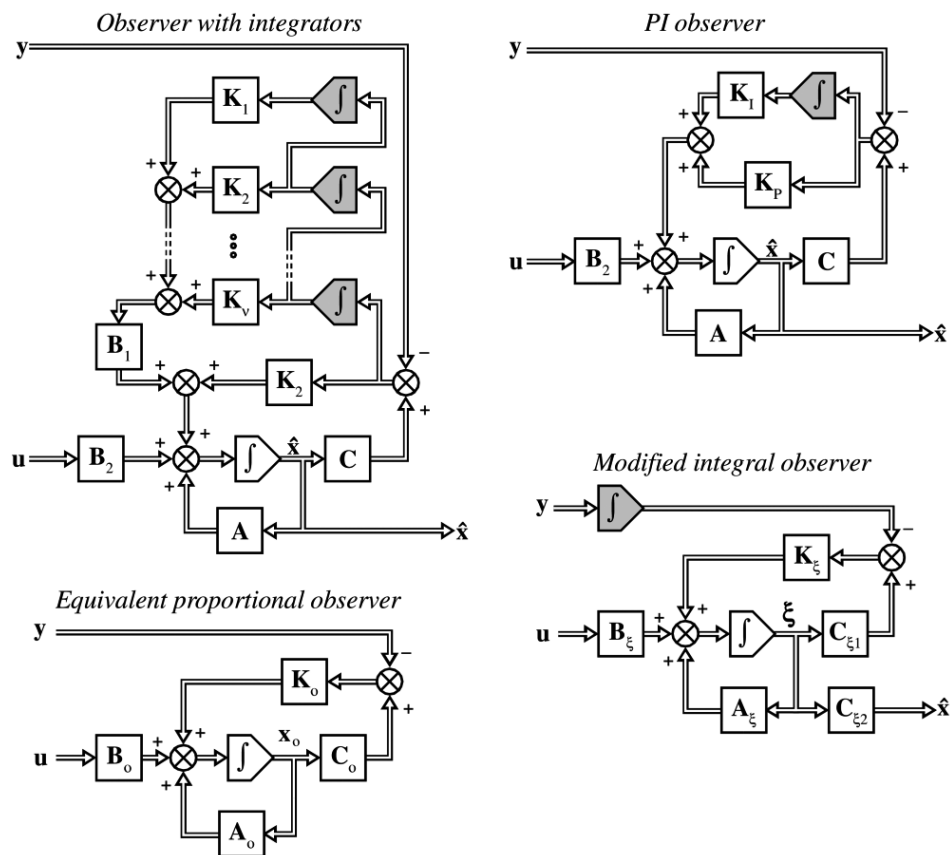

Fig. 1. Block diagrams of observers with various types of feedbacks, modified integrators are marked with grey background

5. Experimental investigations

The presented observers have been tested in a multiscalar control system [10, 12]. The block diagram of the applied control system is shown in Fig. 2. Multiscalar state variable x_{21} has the value equal to the square of a rotor flux module. State variable x_{12} is proportional to the electromagnetic torque of the motor t_e . The observer was equipped with the speed adaptation mechanism described

in [1]. Estimation quality may be evaluated based on shapes of the transients of the multiscalar space variables x_{12} and x_{21} . The more disturbed they are, the worse is estimation quality. In particular, in the ideal case, the transient of x_{21} should have the form of a flat line.

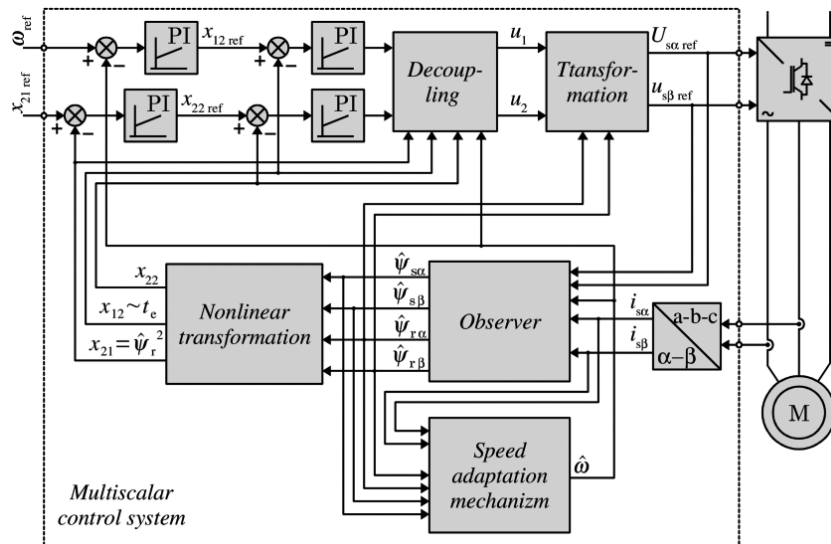

Fig. 2. Block diagram of laboratory system

6. Gain selection criteria

Dynamical properties of the observer are determined by its eigenvalues λ . A gain selection process consists in obtaining such values of observer's \mathbf{K}_o elements that eigenvalues described with (9) were properly placed in the complex plane. Real parts of all eigenvalues must be negative in order to provide the stability of the observer. The greater are absolute values of eigenvalue real parts, the shorter are the time constants of the observer and the stronger reconstruction errors are attenuated. Eigenvalue imaginary parts are equal to proper vibration pulsations of the observer. It is favorable when imaginary parts are equal to zero, because then the observer is a clearly inertial (non-oscillatory) system, therefore there is no threat of occurrence of resonance that might substantially increase reconstruction errors.

Apart from basic criteria based on eigenvalues, additional ones can also be introduced. For example, it may be concluded from previous research conducted by the authors [5] that the greater is robustness of the observer against measurement noises, the lesser is the value of the quantity named by the authors a matrix amplification index. This quantity is defined with the formula:

$$\|\mathbf{K}_o\|_w = \frac{1}{n_o} \sum_{i=1}^{n_o} \sqrt{\sum_{j=1}^q (\mathbf{K}_o^{(i,j)})^2}, \quad (14)$$

where $\mathbf{K}_o^{(i,j)}$ is the element of the matrix \mathbf{K}_o placed in its i -th row and j -th column.

Other additional criteria can be introduced based on special properties of the observed system. For example, all the matrices of the induction motor described with (1)–(3) are composed of second-order square submatrices of the following form:

$$\mathbf{G} = \begin{bmatrix} a & -b\omega \\ b\omega & a \end{bmatrix}, \quad (15)$$

where \mathbf{G} is the elementary 2-nd order matrix, a and b are real scalars. It can be proven that if the gain matrix of the observer is also built in this way then the observer has identical dynamical properties for positive and negative angular speed ω . Such property is demonstrated by the observer described in [1]. If this criterion is not met, then the eigenvalues of the observer depend on the direction of motor rotation.

7. Optimization gain selection

In order to calculate observer's gains with an optimization method, selection criteria have to be expressed with fitness function. The function proposed by the authors has the form:

$$F = \sum_i k_i F_i, \quad (16)$$

where F_i is the component representing i -th selection criterion and k_i is the weight coefficient. Each function F_i equals zero when a corresponding criterion is met. Its positive value becomes greater, when the achieved solution becomes more distant from the optimal solution. The function F defined in this way always has the minimum value.

A stability criterion is represented with the component:

$$F_1 = \sum_{j=1}^{n_o} \begin{cases} 1 & \text{if } \operatorname{Re}(\lambda_j) > 0 \\ 0 & \text{if } \operatorname{Re}(\lambda_j) \leq 0 \end{cases}. \quad (17)$$

Function F_1 equals zero when all the eigenvalues of the observer are placed in the left part of the complex plane.

Component F_2 is increased, when real parts of eigenvalues become more distant from assumed reference value λ_{ref} :

$$F_2 = \sum_{j=1}^{n_o} |\operatorname{Re}(\lambda_j - \lambda_{\text{ref}})|. \quad (18)$$

An analogous component for imaginary parts is defined with the assumption that the reference value equals zero:

$$F_3 = \sum_{j=1}^{n_o} |\operatorname{Im}(\lambda_j)|. \quad (19)$$

Components F_2 and F_3 describe criteria connected with observer's time constants and proper vibration pulsations.

Robustness of the observer can be increased with application of the component:

$$F_4 = \|\mathbf{K}_o\|_w. \quad (20)$$

The produced fitness function was minimized with a genetic algorithm. The calculation process consists of three stages. First, the form of the gain matrix \mathbf{K}_o has to be assumed. Additional criterion (15) can be applied at this stage. Next, the roots λ_i of characteristic polynomial (9) have to be calculated. In the end, the value of fitness function (16) has to be calculated. All calculations should be performed for several values of angular speed ω , chosen from the expected operation range of the motor.

The eigenvalues and laboratory test results obtained for the observers with integrators are presented in Fig. 3. Observers' gains were selected with the presented optimization method. Additional criterion (15) has been applied, therefore eigenvalue plots are symmetrical in relation to the straight line representing $\omega = 0$.

In Fig. 3 transients of multiscalar state variables are shown. The presented transients were recorded during acceleration of the motor and during reversal performed at low angular speed.

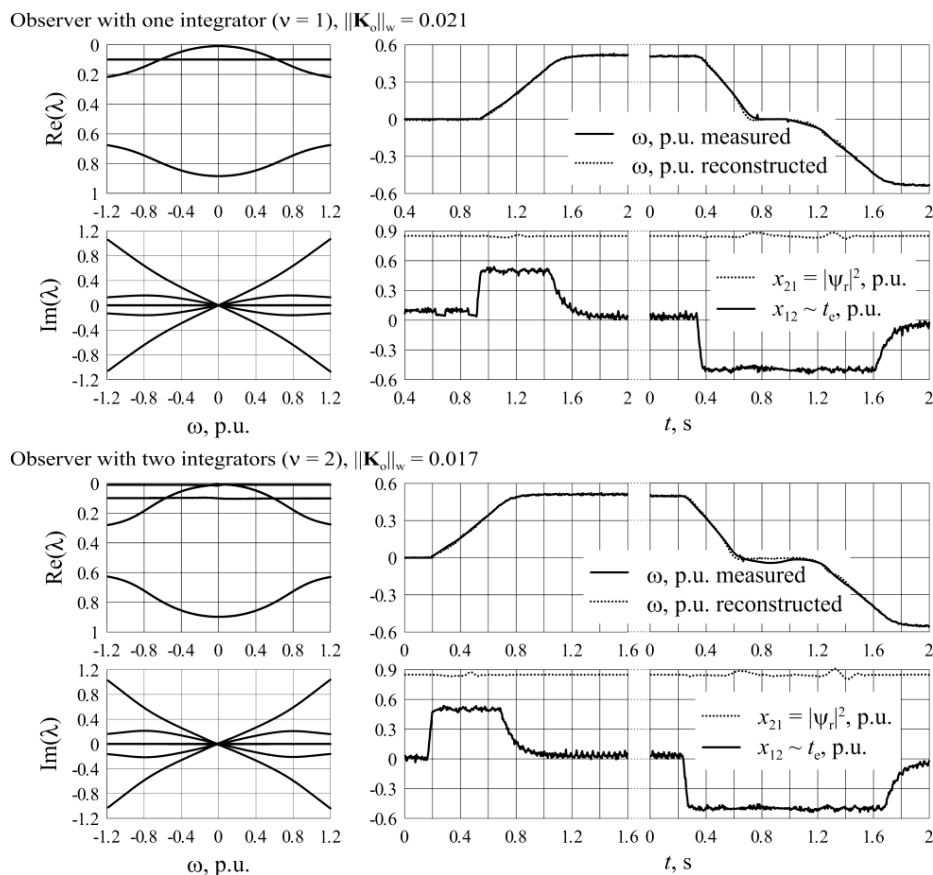

Fig. 3. Eigenvalues and experimental results of the observer with additional integrators with gains selected with genetic algorithm

8. Analytical gain selection

Many of known analytical methods for control system design can be adopted to gain selection of the observer. These methods have one significant drawback, they are relatively easy to apply only when the correction feedback signal is one-dimensional. In the case of observers it means that the observed system should have one output only ($q = 1$). This problem can be solved with use of dyadic transform (described in section 7.1) that should be applied before gain selection performed by such methods (described in 7.2 and 7.3).

8.1. Dyadic transform

The basic idea of the transformation consists in decomposition of the gain matrix \mathbf{K}_o to dyads [12, 13]. Each dyad is a first-order matrix being the product of one of the matrix \mathbf{K}_o columns and corresponding row of an identity matrix:

$$\mathbf{K}_o = \sum_{i=1}^q \mathbf{K}_o^{[i]} \mathbf{1}_q^{(i)} = \underbrace{\sum_{i=1, i \neq j}^q \mathbf{K}_o^{[i]} \mathbf{1}_q^{(i)}}_{\mathbf{K}_d(\kappa)} + \underbrace{\mathbf{K}_o^{[j]} \mathbf{1}_q^{(j)}}_{\mathbf{k}_d(\kappa)} = \mathbf{K}_d(\kappa) + \mathbf{k}_d(\kappa) \mathbf{1}_q^{(j)}, \quad (21)$$

where the superscript $[i]$ denotes the i -th column of the matrix and the superscript $\{j\}$ denotes the j -th row of the matrix. On decomposition, the j -th dyad is treated as unknown and it will be further computed with one of methods described in sections 7.2 and 7.3. All other dyads are summed and create matrix \mathbf{K}_d . Element values of this matrix should be arbitrary assumed. Moreover, parameter κ can be introduced into assumed values, in order to provide an additional degree of freedom that makes it possible to consider additional gain selection criteria. The parameter value is to be chosen at the end of the gain calculation process.

The created \mathbf{K}_d matrix together with matrices \mathbf{A}_o and \mathbf{C}_o describing the observed system defines a mathematical model of a new equivalent observed system with one output, represented by the matrices:

$$\begin{cases} \mathbf{A}_d(\kappa) = \mathbf{A}_o + \mathbf{K}_d(\kappa) \mathbf{C}_o \\ \mathbf{C}_d = \mathbf{1}_q^{(j)} \mathbf{C}_o \end{cases}. \quad (22)$$

The observer of the equivalent system has the form of proportional observer (8) and is described with matrices \mathbf{A}_d , \mathbf{C}_d and column vector \mathbf{k}_d . Application of additional criterion (15) is impossible with this method, this results from the basic idea of dyadic transformation.

8.2. Modified Söylemez–Munro method

In [13, 14] Söylemez and Munro proposed an analytical method for pole placement of a linear control system. This method has been adopted by the authors for observer design. In dyadic transform that reduces a multi-dimensional gain selection problem to a single-dimensional one, the desired j -th dyad represented by column vector \mathbf{k}_d can be calculated with the formula:

$$\mathbf{k}_d(\kappa) = [\Phi(\kappa)^T]^{-1} \mathbf{X}(\kappa)^{-1} \delta(\kappa), \quad (23)$$

where X is the lower-triangular Toeplitz matrix, containing coefficients of the matrix A_d characteristic polynomial:

$$X(\kappa) : X(\kappa)^{(k,m)} = \begin{cases} 0 & \text{if } k < m \\ 1 & \text{if } k = m \\ \mathbf{a}(\kappa)^{\{n_o-k+m+1\}} & \text{if } k > m \end{cases} \quad \text{where } k \in [1; n_o], m \in [1; n_o] \quad (24)$$

and \mathbf{a} is a vector of characteristic polynomial coefficients of the matrix A_d , in which the element with number $n_o + 1$ has been omitted. This element corresponds to the greatest power and from properties of characteristic polynomial it follows that its value always equals 1. Matrix Φ is defined with:

$$\Phi(\kappa) : \Phi(\omega, \kappa)^{[k]} = (A_d(\kappa)^T)^{k-1} (-C_o^{(j)})^T, \quad \text{where } k \in [1; n_o]. \quad (25)$$

Φ must be non-singular. If it is not, calculation of gains is impossible. In such case, assumptions made during dyadic transform must be changed. In (23), vector δ contains differences of coefficients of two characteristic polynomials. The first one is calculated for matrix A_d and denoted as \mathbf{a} . The second one is calculated based on the assumed desired eigenvalues of the observer λ_{ref} , and is represented by vector α :

$$\delta(\kappa) = \alpha - \mathbf{a}(\kappa). \quad (26)$$

Since parameter κ is present, equation (23) has to be evaluated symbolically, thus software for computer aided symbolical calculations must be applied. Another parameter that appears in (23) is the angular speed of the motor ω . Calculated \mathbf{k}_d vector ensures that all the eigenvalues of the observer are equal to reference ones λ_{ref} . Since parameter κ is present, the gain selection problem has an infinite number of solutions. This enables further taking into consideration an additional criterion consisting in minimization of matrix amplification index (14).

The results of the gain selection and laboratory tests obtained for the PI observer are presented in Fig. 4. During the gain selection it occurred that independently of the assumptions made during

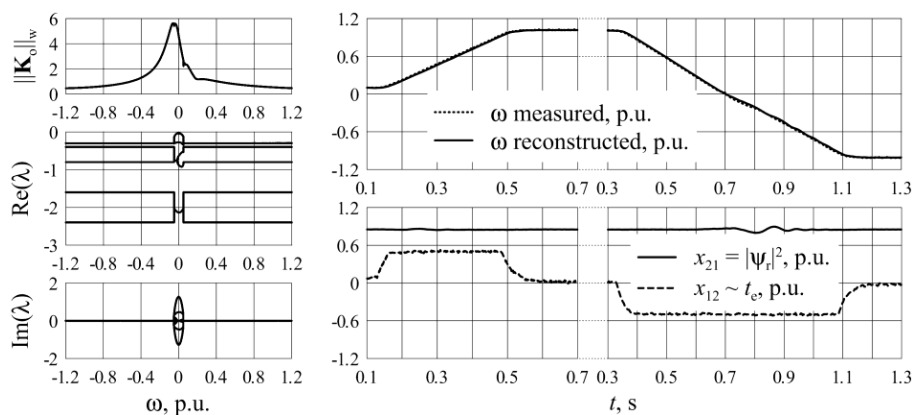

Fig. 4. Eigenvalues and experimental results of the PI observer with gains selected with the method proposed by Söylemez and Munro

the dyadic transform, matrix Φ was always singular for angular speed $\omega = 0$. This is why the eigenvalues are different from reference ones in close neighborhood of this speed. From the recorded transients it can be seen that these differences have no impact on proper operation of the control system, because even for $\omega = 0$ the observer remains stable ($\text{Re}(\lambda < 0)$).

8.3. Basis transformation method

The same dynamic system can be described with (1) in many equivalent ways that differ in a set of chosen state variables contained in the state vector \mathbf{x} . In particular, when two different state vectors are linear combinations of each other, in both cases the matrices in (1) have different values; nevertheless the eigenvalues are the same. The set of state variables defines the base of the system and transformation of the basis has no impact on its dynamical properties. Basis transformation of the observed system after the dyadic transform, described with matrices A_d and C_d , results in matrices A_{dt} and C_{dt} :

$$\begin{aligned} A_{dt}(\kappa) &= T(\kappa)^{-1} A_d(\kappa) T(\kappa), \\ C_{dt} &= c C_d T(\kappa), \end{aligned} \quad (27)$$

where T is the basis transformation matrix that must be non-singular. The principle of the basis transformation method consists in finding such transformation matrix that transforms matrices of the system into canonical forms:

$$\begin{aligned} A_{dt}(\kappa) &= \begin{bmatrix} \mathbf{0}_{1 \times (n_o-1)} & \vdots \\ \text{-----} & \vdots \\ \mathbf{1}_{n_o-1} & \vdots \end{bmatrix} - \mathbf{a}(\kappa), \\ C_{dt} &= [\mathbf{0}_{1 \times (n_o-1)} \quad \mathbf{1}]. \end{aligned} \quad (28)$$

From the definition of characteristic polynomial (9) it may be inferred that gain matrix \mathbf{k}_{dt} of the observer (8) of the system described with matrices (28) is equal to the difference of vectors of characteristic polynomial coefficients:

$$\mathbf{k}_{dt}(\kappa) = \mathbf{a}(\kappa) - \alpha. \quad (29)$$

Thus, in order to calculate observer's gains with the basis transformation method, first transformation (27) must be performed, then gains of the observer for the transformed system have to be calculated with (28), and in the end, reverse transform of the calculated gain vector is to be performed:

$$\mathbf{k}_d(\kappa) = T(\kappa) \mathbf{k}_{dt}(\kappa). \quad (30)$$

The last step is selection of κ parameter, which is performed in the same way as in the Söylemez–Munro method.

The results of the gain selection and laboratory tests obtained for the modified integral observer are presented in Fig. 5. The assumed reference eigenvalues dependent on angular speed of the motor ω .

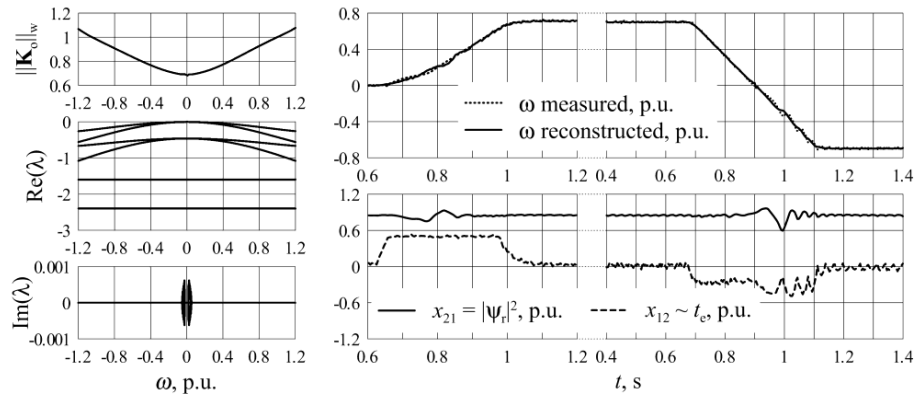

Fig. 5. Eigenvalues and experimental results of the modified integral observer with gains selected with the basis transformation method

9. Summary

The paper recapitulates the results of investigations that have been conducted by the authors in recent years. Three structures of non-proportional observers have been analyzed and applied. Proper operation of the observers has been confirmed with laboratory tests. Complicated structures of the observers result in difficult selection of their gains.

The gains can be computed with three methods developed by the authors in order to meet classic selection criteria based on eigenvalues as well as new ones proposed by the authors. Analytical methods enable more precise pole placement than optimization. However, the optimization with a genetic algorithm is the only one of the proposed methods that fulfils a criterion of symmetry (15). It also enables such selection of the gains that they are independent of the angular speed of the motor.

References

- [1] Kubota H., Matsuse K., Nakano T., *DSP-based speed adaptive flux observer of induction motor*, IEEE Transactions on Industry Applications, vol. 27, no. 2, pp. 344–348 (1993).
- [2] Busawon K.K., Kabore P., *On the design of integral and proportional integral observers*, Proceedings of the American Control Conference, Chicago, USA, pp. 3725–3729 (2000).
- [3] Busawon K.K., Kabore P., *Disturbance attenuation using proportional integral observers*, International Journal of Control, vol. 74, no. 6, pp. 618–627 (2001).
- [4] Białoń T., Lewicki A., Pasko M., Niestrój R., *PI observer stability and application in an induction motor control system*, Bulletin of the Polish Academy of Sciences, Technical Sciences, vol. 61, no. 3, pp. 595–598 (2013).
- [5] Białoń T., Lewicki A., Pasko M., Niestrój R., *Parameter selection of an adaptive PI state observer for an induction motor*, Bulletin of the Polish Academy of Sciences, Technical Sciences, vol. 61, no. 3, pp. 599–603 (2013).
- [6] Guo-Ping J., Suo-Ping W., Wen-Zhong S., *Design of observer with integrators for linear systems with unknown input disturbances*, Electronics Letters, vol. 36, no. 13, pp. 1168–1169 (2000).

- [7] Białoń T., Lewicki A., Niestrój R., Pasko M., *Stability of a proportional observer with additional integrators on the example of the flux observer of induction motor*, *Przeгляд Elektrotechniczny*, vol. 87, no. 4, pp. 142–145 (2011).
- [8] Białoń T., Lewicki A., Pasko M., *Application of the integral Luenberger observer to an induction motor multiscalar control system*, *Przeгляд Elektrotechniczny*, vol. 85, no. 3, pp. 52–55 (2009).
- [9] Boldea I., Nasar S.A., *The induction machine handbook*, CRC Press (2002).
- [10] Morawiec M., Guzinski J., *Sensorless control system of an induction machine with the Z-type backstepping observer*, *IEEE 23rd International Symposium on Industrial Electronics*, pp. 896–901 (2014).
- [11] Hu J., Wu B., *New Integration Algorithms for Estimating Motor Flux over a Wide Speed Range*, *IEEE Transactions on Power Electronics*, vol. 11, no. 5, pp. 969–977 (1998).
- [12] Krzemiński Z., Lewicki A., Włas M., *Properties of sensorless control systems based on multiscalar models of the induction motor*, *COMPEL*, vol. 23, no. 1, pp. 195–206 (2006).
- [13] Munro N., *Symbolic methods in control system analysis and design*, Institution of Electrical Engineers (1999).
- [14] Söylemez M.T., Munro N., *A note on pole assignment in uncertain systems*, *International Journal of Control*, vol. 66, no. 4, pp. 487–497 (1977).