

## Effects of space vector modulation strategy on hybrid (Si-SiC) inverter losses

MICHAŁ BONISŁAWSKI, MARCIN HOŁUB

*Electrical Engineering Department  
West Pomeranian University of Technology  
ul. Sikorskiego 37  
70-313 Szczecin, Poland  
tel.: +48(91)4494805, fax: 48(91)4494317  
e-mail: marcin.holub@zut.edu.pl, http://www.we.zut.edu.pl*

(Received: 02.12.2011, revised: 12.01.2012)

**Abstract:** This work summarizes efficiency measurement results of a full bridge, 3 phase inverter composed of state-of-the-art Si IGBT transistors and Si or SiC diodes. Different (symmetrical and discontinuous) space vector modulation strategies were chosen in order to examine their influence (together with modulation frequency) on inverter losses. Induction machine was used as load, different load points were examined. Results clearly show, that proper modulation strategy, minimizing the switching losses of semiconductor switches, can increase the overall output efficiency at about 1% in case of both silicon and hybrid constructions. The drawback of DPWM approach is connected with the decreased quality of inverter output current. Hybrid technology can also improve the output efficiency at about 1% when compared to traditional constructions, but only in case of elevated switching frequencies. At low frequencies (below 10 kHz) modern semiconductors offer comparable results at much lower device costs.

**Key words:** SVPWM, DPWM, power electronic inverter, SiC diodes, hybrid inverter, wide band gap devices

### 1. Introduction

First wide band gap devices (SiC Schottky diodes by Infineon) were commercially introduced in 2001. Since then SiC has the highest market share among other wide band gap materials. Beside other advantages these devices offer higher temperature operation and lower reverse recovery currents in high-speed applications. Due to the price difference fully controllable switches (based on field effect transistors) are still in research and prototyping phase, but many hybrid constructions were presented using modern silicone transistors and SiC reverse diodes [1-3]. Such a combination offers high performance (up to 33% of loss reduction according to [3], about 19% according to [4]) while limiting the necessary component cost increase.

On the other hand modern control units and dedicated DSPs offer extreme fast response times, hardware based peripheries and high computational power so that complicated modulation algorithms can be implemented. In three phase applications space vector based modulation methods were used for years due to their known advantages. Modulation strategy has a visible impact on inverter losses and proper switching pattern definitions were investigated since 1990 [5-7]. Also in space vector modulation different strategies appeared based on the calculation method and zero vector placement.

This work summarizes test stand measurement results of a hybrid full bridge inverter using different semiconductors and different space vector modulation (SVM) strategies (symmetrical and discontinuous). Characteristics will also include load point dependency and switching frequency influence.

## 2. Modulation strategies

As already mentioned two different strategies were chosen for measurements: space vector symmetrical and discontinuous modulation. As known from the literature any output space vector of the inverter can be obtained inside a given (DC-link voltage related and according to logical states of the inverter valves) hexagon limit when satisfying the condition of proportional active vector use while the zero voltage vector is calculated using the difference between assumed modulation period and calculated time necessary for active states. Basic principle of SVM is depicted in Figure 1.

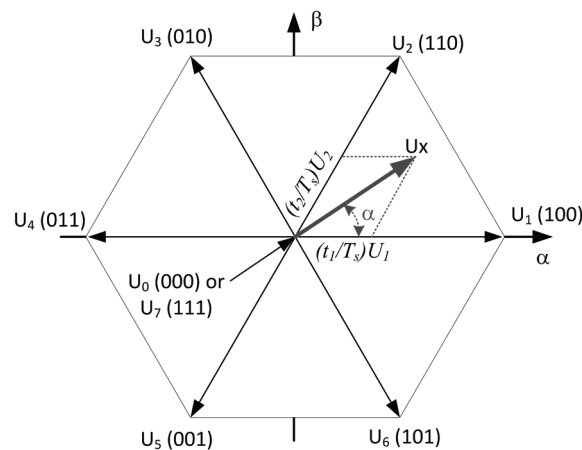

Fig. 1. Basic principle of space vector modulation

According to the principle mentioned above all the time periods are calculated according to formulas:

$$t_1 = \frac{2\sqrt{3}}{\pi} MT_s \sin(60^\circ - \alpha), \quad t_2 = \frac{2\sqrt{3}}{\pi} MT_s \sin(\alpha), \quad (1)$$

where  $t_1$ ,  $t_2$  are active times of inverter vectors  $U_1$  and  $U_2$  respectively,  $T_s$  is the modulation period and  $M$  is the modulation index depicting the ratio of the length of the expected voltage vector  $U_x$  with the respect of the DC link voltage  $U_{dc}$  according to formula:

$$M = \frac{U_x}{\frac{2}{\pi} U_{dc}} \tag{2}$$

Modulation period is completed with the calculation of overall time reserved for zero-voltage vector selection:

$$t_0 = T_s - t_1 - t_2 \tag{3}$$

From this result many strategies are possible. In the first approach (symmetrical SVPWM) calculated time for zero vectors is equally distributed in two symmetrical halves, each divided into two quarters implemented at the beginning, in the middle and at the end of the modulation period. The other possibility is to divide the entire zero voltage vector time into two halves implemented in the modulation period. This group will be further on referred to as DPWM. Additional combinations might include the use of either  $U_0$  or  $U_7$  or both vectors for zero voltage vector state. Graphical representation of both possibilities is depicted in Figure 2.

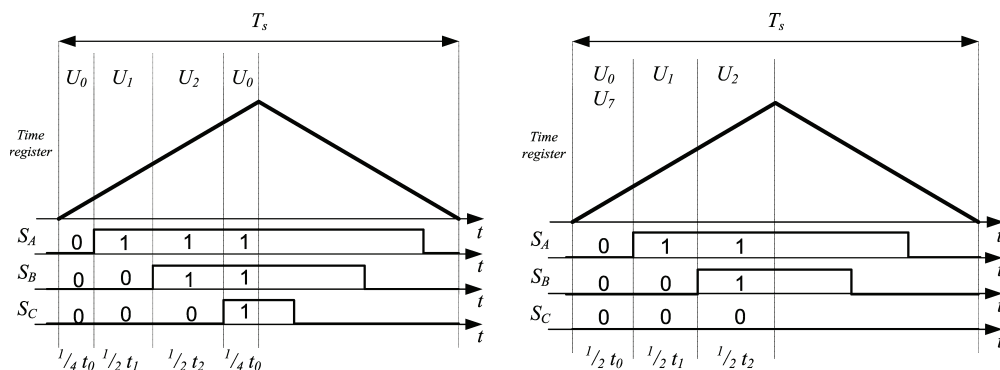

Fig. 2. Symmetrical (left) and discontinuous strategy of the SVM

In consequence, although the same output space vector is obtained different switching patterns are used at the switch level. 6 changes of the inverter state are required for each period of symmetrical SVPWM and only 4 in the case of DPWM. Overall influence on inverter efficiency of both approaches was examined together with the use of different modulation period length (frequency) and different points of load.

### 3. Experimental results

Experiments were led on an inverter prototype using IGBT switches, Si and SiC reverse diodes. Parameters of devices used are summarized in Table 1.

Table 1. Main parameters of components used in experimental phase

Device	Device symbol	Rated voltage [V]	Rated current [A]
IGBT	IGW15N120H3	1200	15
Si diode	DSEI 12-12 A	1200	11
SiC diode	IDH08S120	1200	7.5

Norma 5000 power analyzer was used in the DC-Link and on phase-outputs of the inverter in order to measure the overall inverter efficiency, induction motor linked with a dc-generator was used as the load. Load power was controlled using the power electronic adjustable load [8, 9]. TI C2000 platform was used for control system implementation. Overall experimental setup and final construction are given in Figure 3.

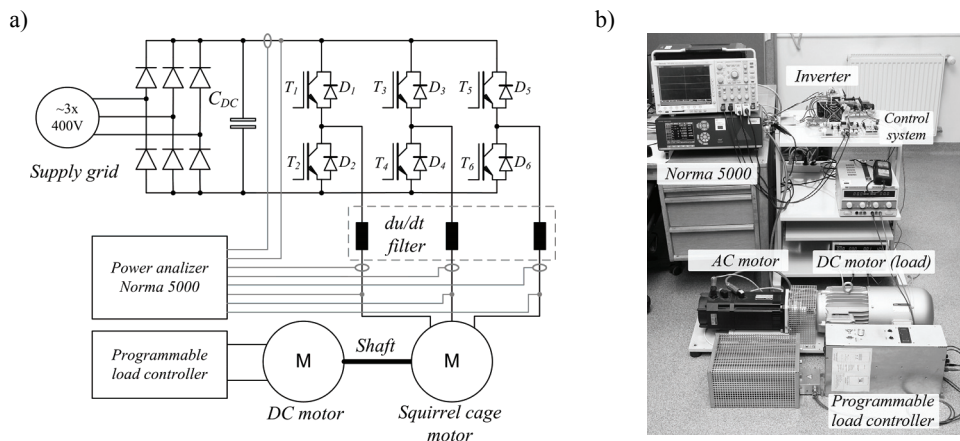

Fig. 3. Test stand setup: a) basic configuration; b) final construction

First set of experiments was led in order to obtain the dependency of overall inverter efficiency as a function of the point of load (output power), modulation frequency and modulation strategy in case of all-Si construction. Measurement results are given in Figure 4.

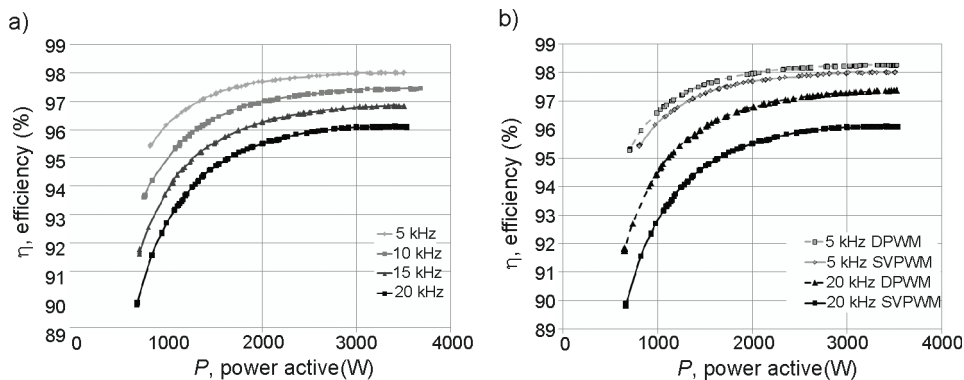

Fig. 4. Efficiency of an all-Si inverter as a function of: a) point of load and modulation frequency; b) modulation strategy

As can be denoted increasing modulation frequency linearly increases switching losses therefore lowering the overall output efficiency. An increase from 5 to 20 kHz led to a drop of efficiency from 98 to 96%. Proper modulation strategy can limit this negative effect enlarging the output efficiency to over 97%. Drawbacks of that approach are connected with lowered output current quality when compared to classical, symmetrical SVPWM.

After completing the first measurement series second set was conducted with identical load and inverter construction but with a hybrid Si-SiC (silicon power IGBT transistors and SiC diodes) semiconductors. Main results are presented in Figure 5. Figure 6 summarizes most important results for both semiconductor sets examined.

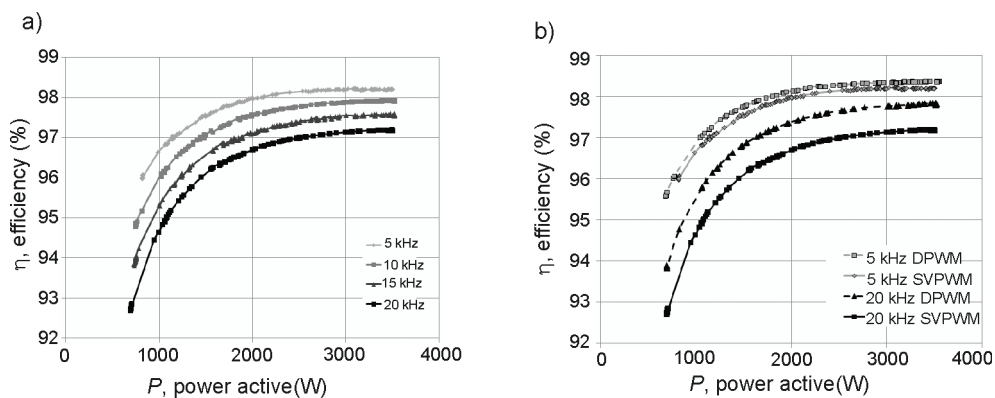

Fig. 5. Efficiency of hybrid Si-SiC inverter as a function of: a) point of load and modulation frequency; b) modulation strategy

As can be seen also in case of hybrid construction the reduction of output efficiency is a linear function of the switching frequency, but in this case (due to limited diode recovery current) the drop is only 1% point. DPWM strategy can also somewhat limit this effect enlarging the efficiency to 97.8% even in the case of 20 kHz modulation frequency. Figure 6 gives a comparison of efficiency measurements in case of symmetrical SVPWM but with varying semiconductor technologies.

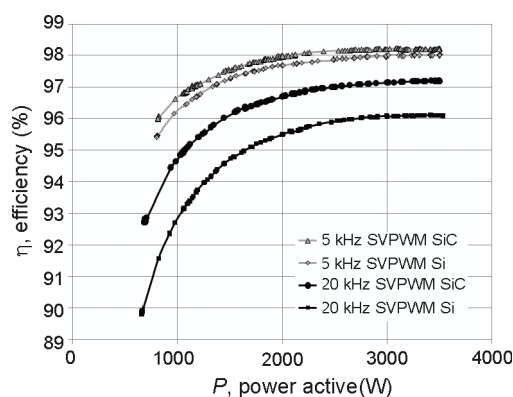

Fig. 6. Efficiency as a function of semiconductor set

As can be denoted the benefit is over 1% in case of 20 kHz modulation frequency and only about 0.2% in case of low modulation frequency (5 kHz).

#### 4. Summary

From 2001 a rapidly growing number of SiC devices is commercially available. Due to the higher price of these devices in retail distribution their industrial use is still limited. First commercially available SiC JFETs and MOSFETs are also present. SiC power diodes used in this experiment were 10 times more expensive than the Si based devices. Power transistors are  $5 \div 10$  times more expensive then the Si versions at current time.

Results of conducted measurements clearly show, that proper modulation strategy, minimizing the switching losses of semiconductor switches, can increase the overall output efficiency at about 1% in case of both silicon and hybrid constructions. The drawback of that approach is connected with the decreased quality of inverter output current. Output current waveforms and their FFT analysis are depicted in Figure 7.

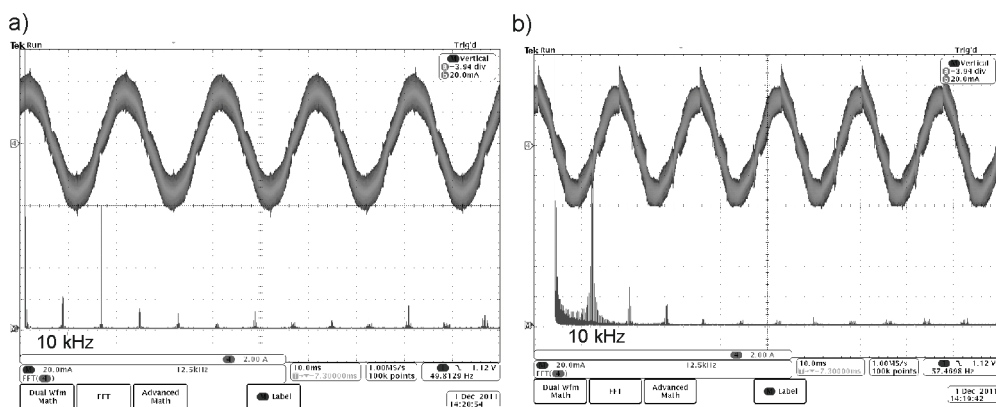

Fig. 7. Output current waveform and the FFT analysis in case of: a) SVPWM, b) DPWM

Tektronix DPO 4054 was used for harmonics measurements. Hybrid technology can improve the output efficiency at about 1% when compared to traditional constructions, but only in the case of elevated switching frequencies. At low frequencies (below 10 kHz) modern semiconductors offer comparable results at much lower device costs.

#### Acknowledgements

This project was financed by the National Centre for Research and Development, Poland (NCBiR), agreement nr ODW-5080/B/T02/2011/40, application nr N N510 508040.

#### References

- [1] Teresa Sierra M., Gabiola I., Pujana A. et al., *Analysis of energy losses for SiC and Si diodes in half-bridge modules and future applications*. EPE, Birmingham, UK (2011).

- [2] Changl H.-R., Hannal E., Radun A.V., *Development and demonstration of silicon carbide (SiC) motor drive inverter modules. power electronics specialist conference. PESC '03* (2003).
- [3] Ozpineci B., Sudhan Chinthavali M., Tolbert L.M., *A 55-kW three-phase inverter with Si IGBTs and SiC schottky diodes. IEEE Transactions on industry applications* 45(1) (2009).
- [4] Nowak M., Rąbkowski J., Barlik R., *Power electronic converters with silicon carbide elements. Elektronika* 6 (2009).
- [5] Berringer K., Marvin J., Perruchoud P., *Semiconductor power losses in AC inverters. Industry Applications Conference, 1995. Thirtieth IAS Annual Meeting, IAS '95. Conference Record of the* (1995).
- [6] Kolar J.W., Ertl H., Zach F.C. *Influence of the modulation method on the conduction and switching losses of a PWM converter system. IEEE Transactions on Industry Applications, Nov/Dec 1991, 27(Issue: 6): 1063-1075* (1991).
- [7] Trzynadłowski A.M., Legowski S. *Minimum-loss vector PWM strategy for three-phase inverters. IEEE Transactions on Power Electronics* 9(1), Jan (1994).
- [8] Hołub M., Bonisławski M., *Dual-mode controller for a power electronic load system. 7th Workshop on Advanced Control and Diagnosis: ACD 19-20 November 2009, Zielona Góra* (2009).
- [9] Bonisławski M., Hołub M. *Programmable load controller for dc machines. Maszyny Elektryczne: zeszyty problemowe* 88: 159-163 (2010).